

LUMINOS
INDUSTRIES LTD.

I1000 1-Axis Positioner User Manual



Table of Contents

Introduction to the I1000 Photonics Positioner	1
Feature Summary	1
Getting Started	1
Reading the Micrometers	1
Connecting an Automated Positioner	2
Actuator Control	3
Mounting the Positioner.....	3
Mounting Devices and Accessories	3
Accessories	3
I1000 Specifications.....	4
Stepper Motor Actuators.....	5
Actuators with Built-In Controller (A and B Type).....	5
Included Software	5
Manual Control	5
Actuators Without a Controller (AM and BM Type)	6
Actuator Specifications	6
Available Options	7
Dimensional Drawings.....	8
Unpacking and Transportation.....	10
Locking Strip Removal	10
Contact Us.....	11
Mailing Address.....	11
Business Hours.....	11
Phone Contacts.....	11
Email Contacts	11
Warranty	12

Table of Figures

Figure 1 - Connecting an Automated Positioner (A and B type actuators)	2
Figure 2 – I3000/I3005 3-Axis Positioner	4
Figure 3 – Mini-din Actuator Connection	6
Figure 2 – I3000/I3005 Positioner (manual) Dimensions - Front & End.....	8
Figure 5 – I3000/I3005 Positioner (manual) Dimensions - Top & Bottom.....	8
Figure 4 – I3000/I3005 Positioner (stepper motor) Dimensions - Front	9
Figure 5 – I3000/I3005 Positioner (stepper motor) Dimensions - Top	9
Figure 8 – Unpacking.....	10

Introduction to the I1000 Photonics Positioner

Able to handle loads of up to 1 kg, the I1000 single axis stage provides a stable platform for many straight-forward positioning tasks. A large travel of 12.7 millimeters (1/2 inch), makes the I1000 suitable where coarse alignment is required. The dual flexure design ensures extremely linearity and eliminates the need to compensate the arcing motion associated with single flexure designs. Furthermore, the flexure design is essentially frictionless and does not exhibit any hysteresis or stiction of typical roller-bearing stages. Internal damping makes the I1000 insensitive to vibration allowing it to be used on a typical bench (without an optical table).

Feature Summary

- All damped flexure
- Manual or fully automated
- Frictionless
- Internal viscous damping
- Insensitive to dust
- Zero arc-error
- Zero backlash
- Resolution enhancing for highest resolution at lowest cost
- 10nm resolution when fitted with a differential micrometer
- Stepper Motor Actuator delivering 0.1µm per micro step

With positioning this easy... the possibilities are endless.

Getting Started

Before unpacking the positioner, please read Unpacking and Transportation on page 10.

Reading the Micrometers

The following table gives the conversion necessary to interpret the numbers read from the micrometer.

Axis	Smallest Division (A)		1 Rotation (B)	
Z	0.001	inches	0.025	inches

Each line on the shaft of the micrometer corresponds to one rotation. The “smallest division” refers to the divisions on the knob of the micrometer. Clockwise rotation of each micrometer causes movement in a positive direction as shown in Figure 2 (pg. 4).

To calculate the position, count the number of divisions on the shaft between the current position and zero. Multiply that number by the movement per rotation (B) given in the table above. Then, count the number divisions on the knob from zero; multiply that

number by the movement per smallest division (A in the table above). Add the two products calculated to give the position. The formula is summarized as:

$$\text{Position} = (\text{Shaft_Divisions} \times B) + (\text{Knob_Divisions} \times A)$$

Note: If the coarse adjustment of the X or Y axis is moved, the position read from the micrometer of that axis will not be the same physical position as before moving the coarse adjustment.

Connecting an Automated Positioner

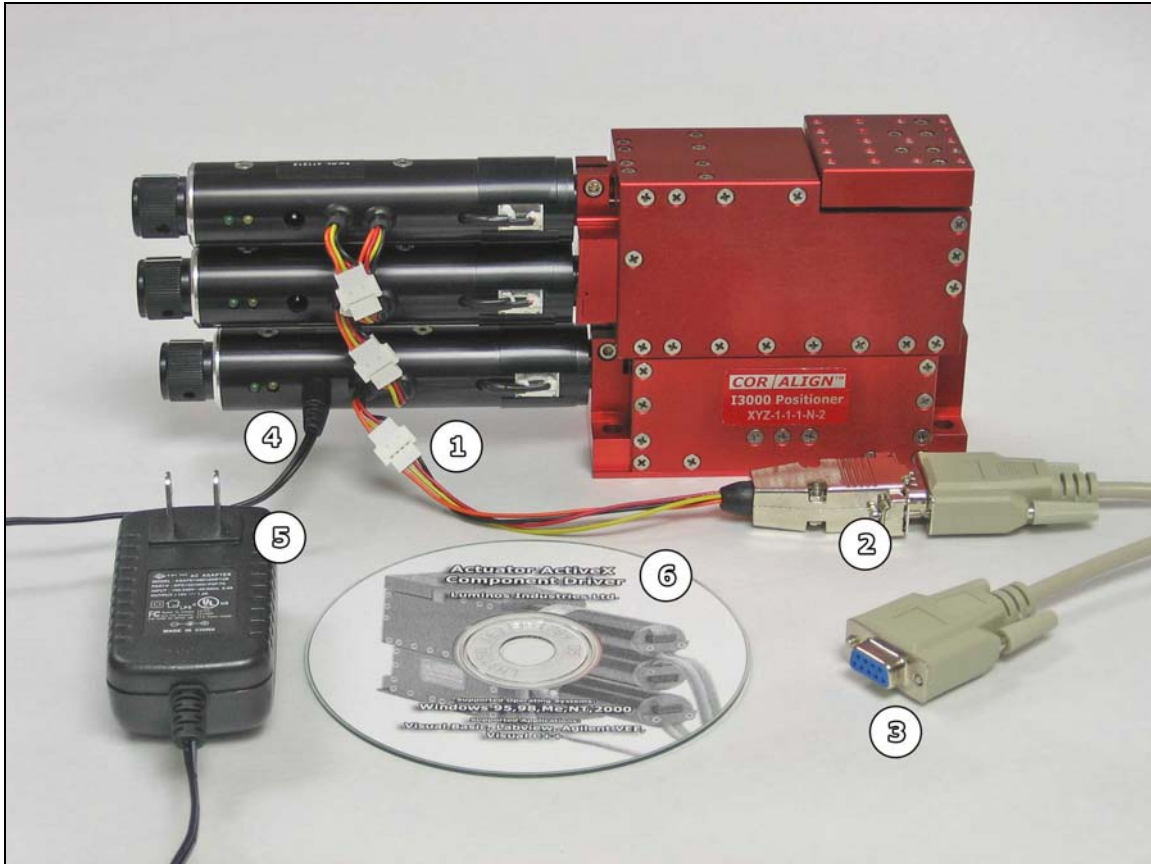

Figure 1 - Connecting an Automated Positioner (A and B type actuators)

To connect your positioner, use the following steps:

1. Connect the 9-pin adapter with the matching white connector to white connector on the bottom actuator closest to the manual knob. On any positioner with more than one axis, this will be the only white connector available on the bottom actuator. (Do not disconnect actuators that are already connected).
2. Connect the other end of the adapter (a female DB9 9 pin connector) to the 9-pin serial extension cable.
3. The end of the cable is a standard 9-pin female serial connection and should connect to one of the serial ports on the back of the computer (or to a Serial-USB adapter to utilize a USB port instead).

4. Connect the 12-16V DC (minimum 800mA) power adapter to the bottom actuator. The rest of the actuators are power through the daisy chain.
5. Plug the power adapter into a standard receptacle.
6. Install the software driver using the CD provided. Help for using the driver is included as part of the installation.

Actuator Control

The documentation for actuator control is included in the accompanying compact disc (if applicable). This format allows easy access from within most software development environments.

Mounting the Positioner

The I1000 mounts using ¼-20 screws on 1 inch and 4 inch centers (see Figure 5 – I3000/I3005 Positioner (manual) Dimensions - Top & Bottom, pg 8)

Mounting Devices and Accessories

The device mounting plate (shown in Figure 2, pg. 4) is where devices and accessories are mounted. For dimensions, see Figure 5 on page 8.

Accessories

There are many accessories available including a contact sensing system for sensing very small forces in the Z (focal) direction. Contact us if there is an accessory you require.

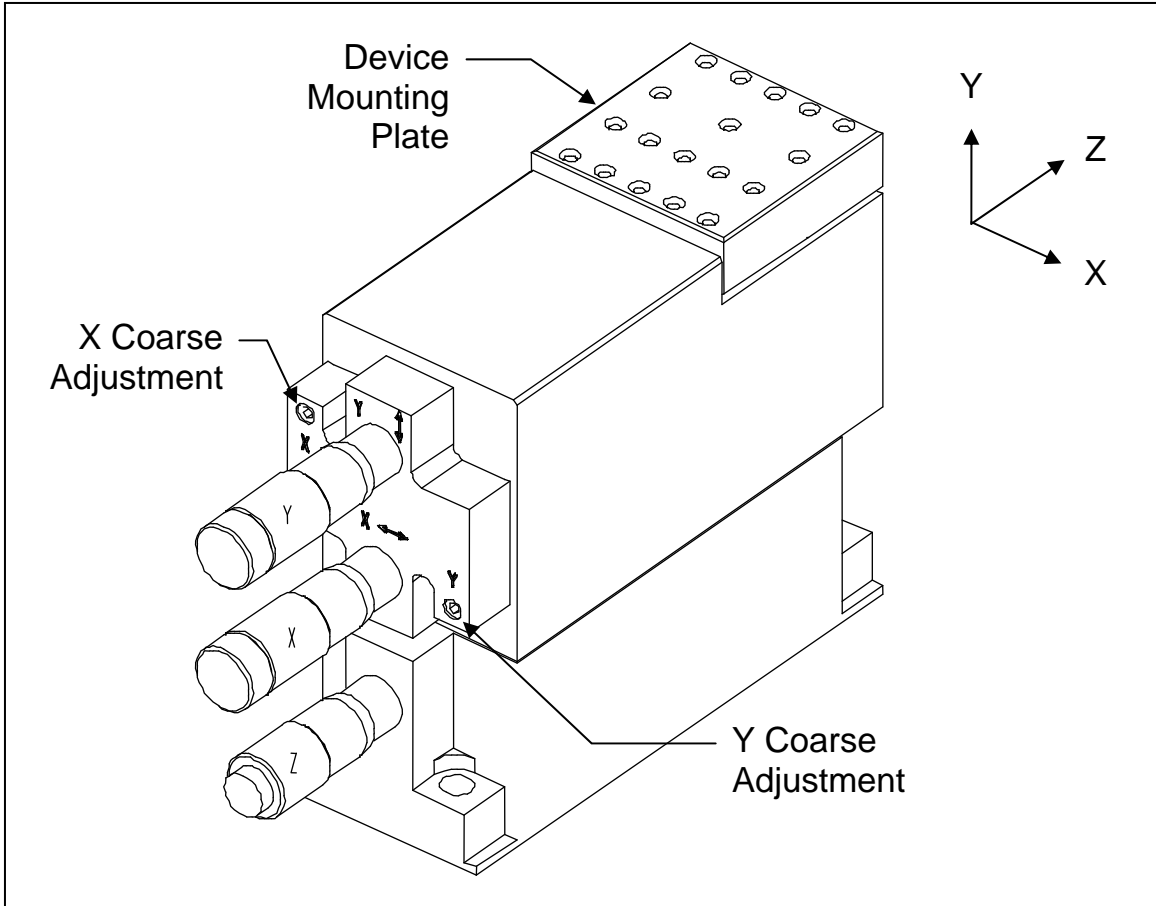

Figure 2 – I3000/I3005 3-Axis Positioner

I1000 Specifications

Travel			
Axis	Actuator ¹	Coarse	Total
Z – focus	12.7mm (0.5")	N/A	12.7mm (0.500")
Setability ² (Micrometer)			
Axis	Resolution	Movement /Division	
Z	0.25 micron (10μ-inch)	0.001"	
Resolution (Stepper Motor – A Type)			
Axis	Resolution	Total Steps	
Z	100nm (4μ-inch)	128 000	
Stage Configuration & Arc Error Motion			
Axis	Flexure Type	Arc Error	
Z	Dual	None - True Linear Motion	
Linear Stiffness			
Along Axis	Stiffness	Comments	
Z	130 kN/m	measured at the rotation center	
Y	95 kN/m	measured at the rotation center	
X	40 kN/m	measured at the rotation center	

Torsional Stiffness		
<i>About Axis</i>	<i>Stiffness</i>	<i>Comments</i>
Z – roll	75Nm/rad	measured at the rotation center
Y – yaw	100Nm/rad	measured at the rotation center
X – pitch	130Nm/rad	measured at the rotation center
Maximum Load		
<i>Static Load</i>	<i>Transient Load</i>	<i>Comments</i>
2.2 lbs (1kg)	10 lbs (4.5kg)	stage must be protected from shock loading during transport and usage
Physical Properties		
<i>Characteristic</i>	<i>Specifications</i>	<i>Comments</i>
Construction	Aluminum	6061 & 7075 - T6 anodized
Weight	1.0kg	Approximate
Body Dimensions	4.50" x 1.75" x 3.80"	LxWxH excluding micrometers
Mounting Height	3.94"	Base to top of mounting plate
Mounting Configuration - Imperial	0.26" dia. holes	1.00" x 4.00" ³ centers
Mounting Configuration - Metric	6.6mm dia. holes	25mm x 100mm centers
Concurrent Rotation Center	1/2"	Above top of mounting plate
	1"	Out from end of mounting plate

¹ 'Actuator' refers to a micrometer or stepper motor.

² Operator dependent

³ Compatible with 1.00" grid optical tables, units mount on 2" intervals with 0.25" allowance for routing of cables etc.

Stepper Motor Actuators

Actuators with Built-In Controller (A and B Type)

The A and B type actuators do not require an external stepper motor driver - these slim actuators actually contain an onboard RS-232 controller which interfaces directly with any standard PC serial port (or USB port with a low cost adapter). Each Positioner is shipped with a 15 Volt, 1 Amp DC Voltage adapter, a 4-pin Molex to 9-pin serial adapter, and a 2m 9-pin extension.

Included Software

An included ActiveX/COM™ software component makes it easy to get up and running quickly in any windows based development environment (including Visual Basic, Labview, and C++, or any of the .NET languages).

Manual Control

A convenient knob at the end of the unit permits manual control. During a manual move the actuator constantly updates the connected computer with its position. If accidental movement is a concern, the manual control can be enabled and disabled via computer control.

Actuators Without a Controller (AM and BM Type)

The AM and BM type actuators are equivalent to the A and B type actuators without controllers. They are provided with direct connections to the two phases of the bipolar stepper motor (4 wires) and a Hall Effect limit sensor (3 wires) through a male 8-pin mini-din connector.

This option allows those with an existing system for driving stepper motors to avoid changing over to RS-232 based control. However, for new applications, this option is not recommended due to the high cost of separate controllers.

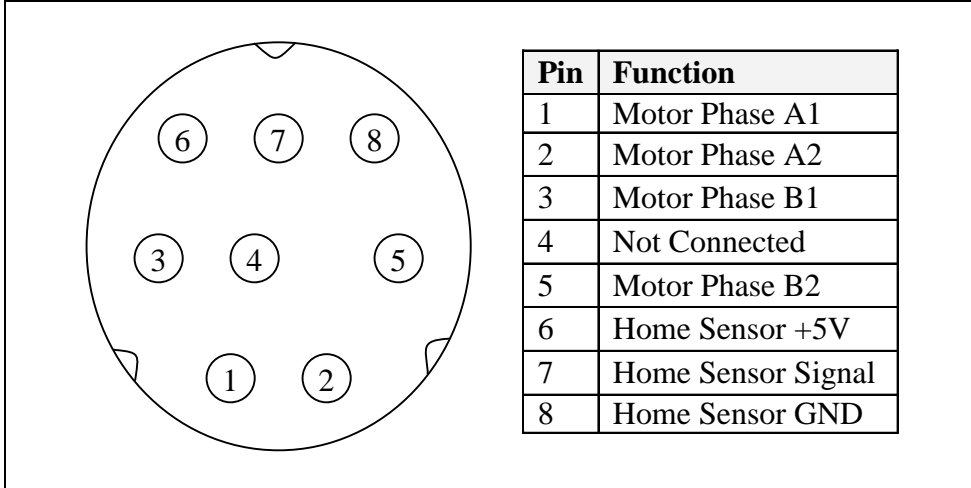

Figure 3 – Mini-din Actuator Connection

Actuator Specifications

Description	Actuator Type			
	A	AM	B	BM
Motor Type	Bipolar Stepper			
Built-in Controller	Yes	No	Yes	No
Steps Per Revolution	48			
Motion Per Step	6.35 μ m		12.7 μ m	
Power Per Phase	1.7W			
Resistance Per Phase	84 ohms		14.7 ohms	
Current per Phase	140 mA		340 mA	
Inductance per Phase	55 mH		8.5 mH	
Accuracy	< 12 μ m		< 16 μ m	
Backlash	< 4 μ m		< 8 μ m	
Repeatability	< 0.4 μ m		< 0.8 μ m	
Power Supply	12V-16V DC unregulated 2.1mm center positive plug (A and B type only)			
Current Draw	Idle: 100 mA Moving: 320 mA			

Table 1 - Actuator Specifications

Available Options

Z Actuator

Manual Imperial Micrometer (default)

*A micrometer where the smallest division is 0.001 inches
(0.025" per revolution)*

Differential Micrometer (Imperial)

*A double threaded micrometer for increased resolution where the smallest
division is 0.00002 inches.*

Stepper, Fine Travel, 0.1 μ m microstep, RS-232 Onboard Controller

Stepper, Long Life, 0.2 μ m microstep, RS-232 Onboard Controller

Stepper, Fine Travel, 6.4 μ m fullstep, Direct Mini-DIN 8

Stepper, Long Life, 12.8 μ m fullstep, Direct Mini-DIN 8

Mounting Axis

Horizontal (default)

The positioner is balanced in the horizontal and upright position.

Vertical

*The positioner is balanced with the micrometers pointing up. This
configuration requires more preload on the z-axis.*

Dimensional Drawings

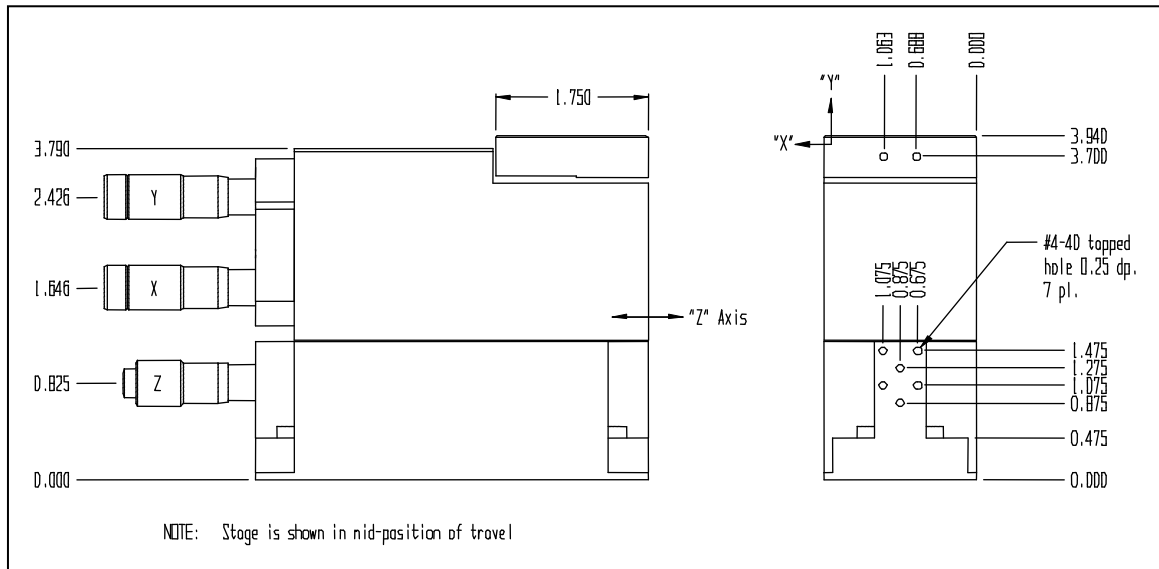

Figure 4 – I3000/I3005 Positioner (manual) Dimensions - Front & End

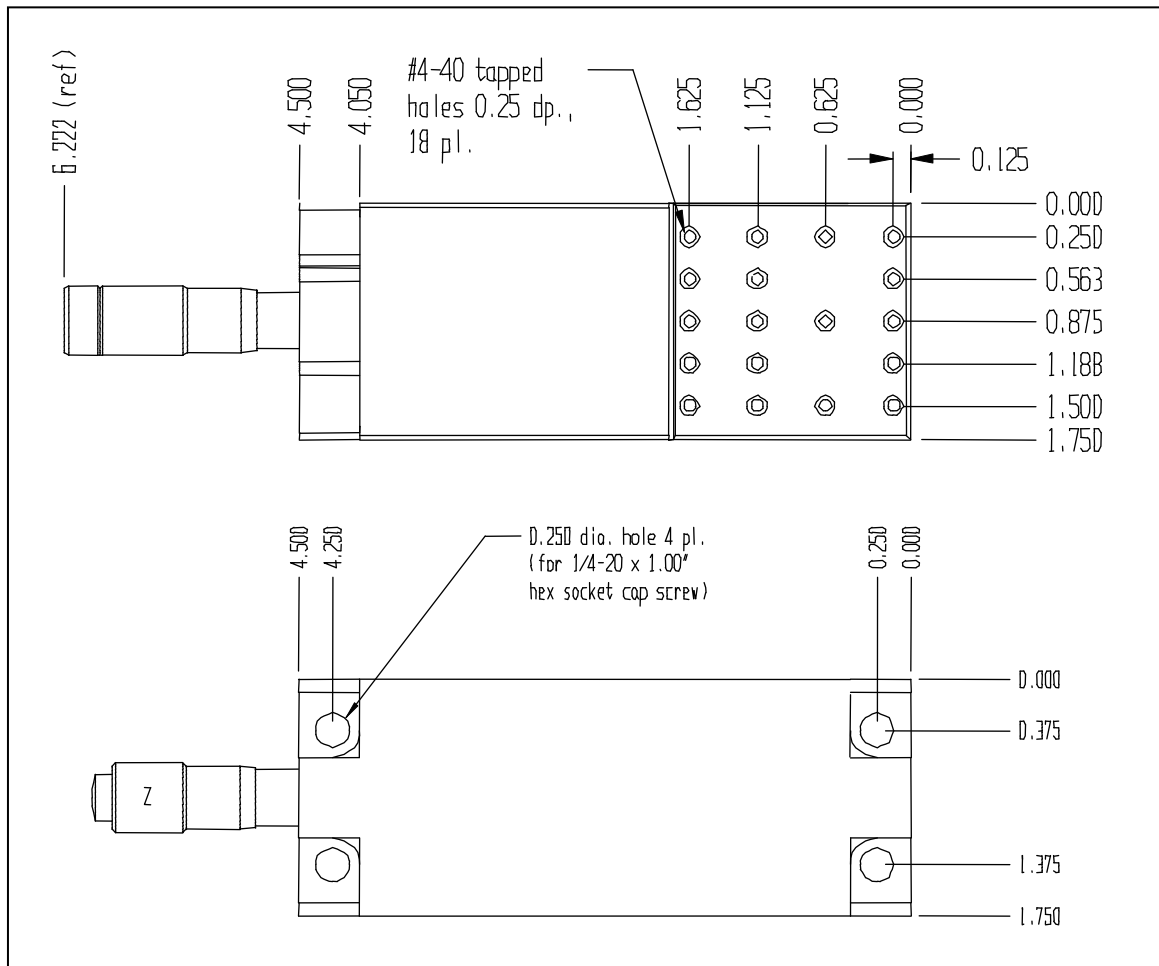

Figure 5 – I3000/I3005 Positioner (manual) Dimensions - Top & Bottom

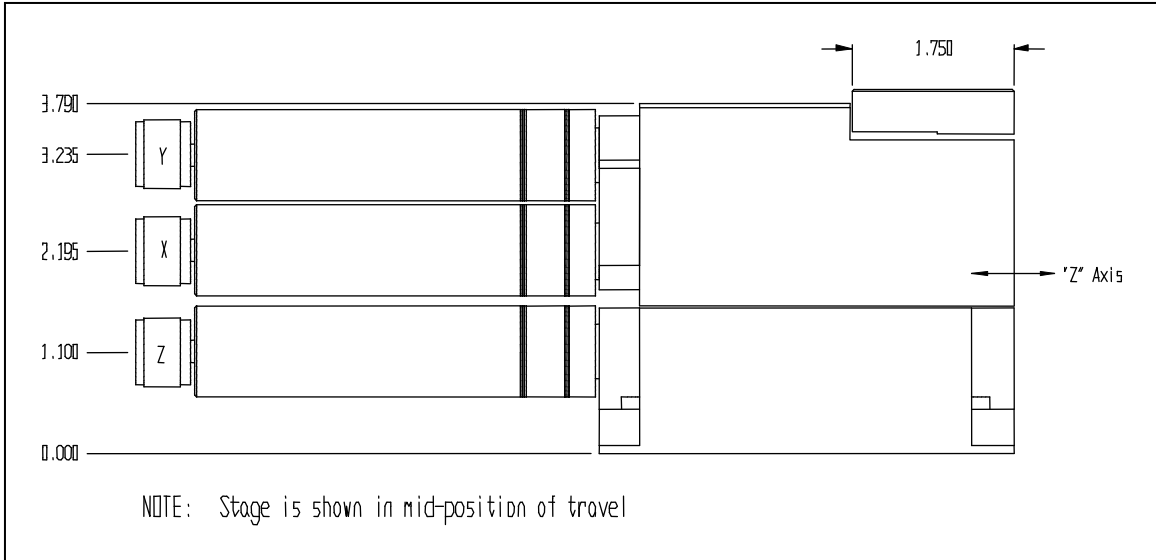

Figure 6 – I3000/I3005 Positioner (stepper motor) Dimensions - Front

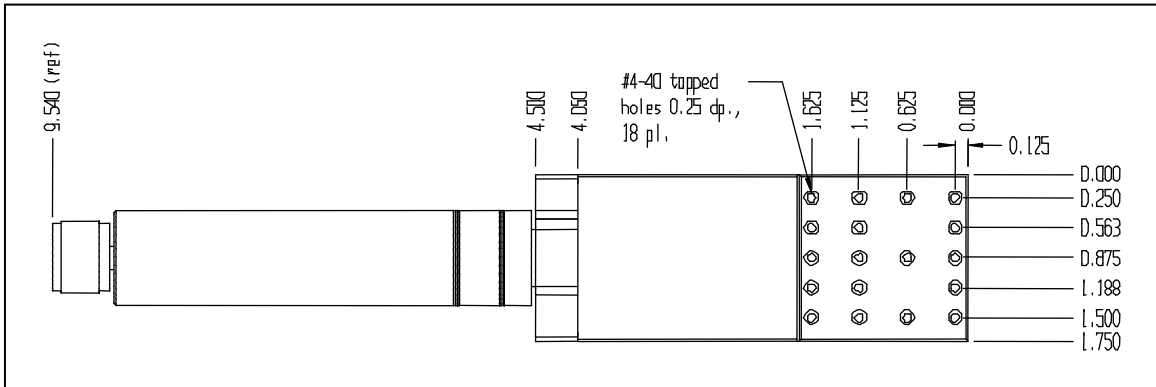

Figure 7 – I3000/I3005 Positioner (stepper motor) Dimensions - Top

Unpacking and Transportation

Do not discard packaging! The warranty is void if a Positioner is not shipped in the original packaging.

Locking Strip Removal

To prevent damage to the Z axis linkage during transportation a plastic locking strip is inserted between the upper and lower part of the unit (see Figure 8, below). To remove the locking strip, apply hand force to the upper portion of the unit (Z axis direction), remove locking strip and carefully allow the unit to return to its pre-loaded position. This procedure is applicable to all positioner types.

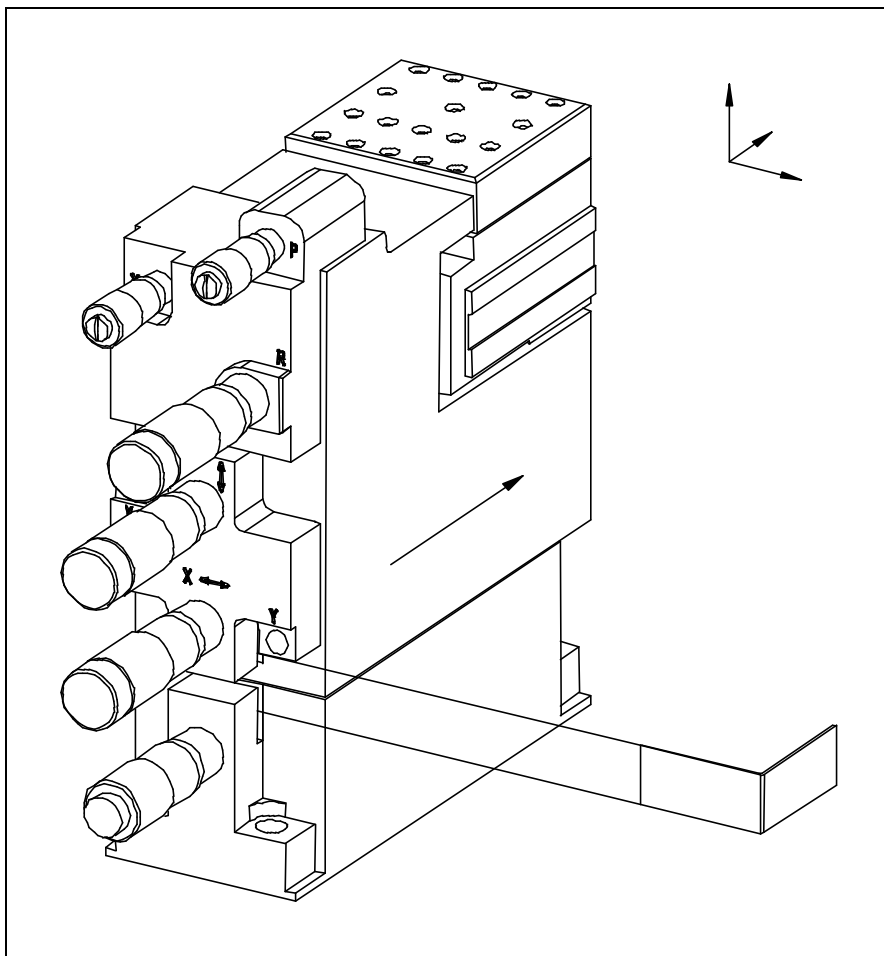

Figure 8 – Unpacking

Contact Us

Thank you for purchasing a Luminos product. We want to ensure your experience is a positive one. If you have any questions, concerns, or comments do not hesitate to contact us.

Mailing Address

Luminos Industries Ltd.
8-58 Antares Drive
Ottawa, Ontario
K2E 7W6 - Canada

Business Hours

Monday to Friday: 8:00am-4:30pm EST

Phone Contacts

Telephone: 1 (613) 225-7661
Fax: 1 (613) 225-3391

Email Contacts

Sales: sales@luminosindustries.com
General Inquiry: info@luminosindustries.com
Support: support@luminosindustries.com

Warranty

All items manufactured by Luminos Industries Ltd. are warranted to meet Luminos Industries' published specifications and to be free of defects in materials and workmanship as defined in the specifications for 90 days after delivery. Luminos Industries Ltd. will, at its own option, repair or replace without charge any listed item discovered to be defective.

Luminos Industries Ltd. will not be held liable for any loss whatsoever beyond the purchase price paid by the buyer for the goods to which claim is made. Luminos Industries does not give implied warranties of merchantability, fitness for a particular purpose, or of any other nature in connection with the sale of any Luminos Industries Ltd. products.

Products not returned in original packaging will void this warranty.

This warranty does not extend to cover damage resulting from alteration, misuse, negligence, abuse, normal wear and tear, or accident.

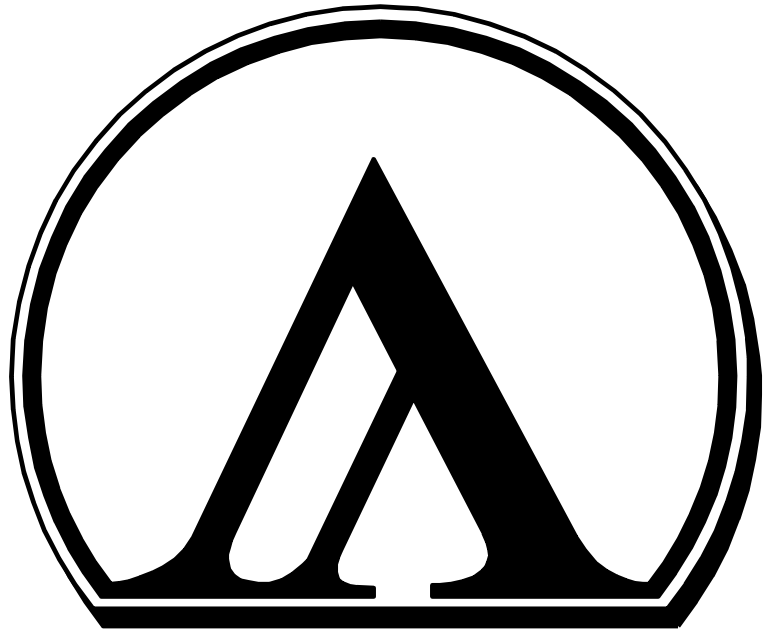

LUMINOS
INDUSTRIES LTD.

**58 Antares Drive
Ottawa, Ontario
Canada
K2E 7W6**

**613 225 7661 – tel
613 225 3391 – fax**

**www.luminosindustries.com
info@luminosindustries.com**